



















More information on the website  
radwag.com/it/info,w1,IKY

## Bilancia WLY 0,6/1,2/PGC/D2



### funzioni

- |   |   |  |  |
|---|---|--|--|
|  Dosing                  |  Labelling             |  Plus/Minus Control     |  Percent Weighing |
|  Totalizing              |  Parts counting        |  Peak hold              |  Formulation      |
|  Newton unit measurement |  Statistics            |  Checkweighing          |  IR sensors       |
|  Animal weighing         |  Differential weighing |  Packaged Goods Control |  ALIBI Memory     |

### foglio di calcolo

Metrological parameters	
Capacità massima [Max]	0,6 / 1,2 kg
pesata minima	5 g
Divisione	0,1 / 0,2 g
intervallo di tara	-1,2 kg
Intervallo di verifica della bilancia	0,1 / 0,2 g
Ripetibilità	0,1 / 0,2 g

<b>Metrological parameters</b>	
linearita	±0,1 / 0,2 g
tempo di stabilizzazione	3 s
Calibrazione	external
Classe OIML	II
<b>Physical parameters</b>	
display	5,7" resistive colour touchscreen
Dimensioni del piatto di pesata	195×195 mm
Packaging dimensions	490×300×150 mm
Peso netto	2,7 kg
Peso lordo	3,6 kg
<b>Construction</b>	
<b>Communication interface</b>	
interfaccia	2×RS232, 2×USB-A, Ethernet, 4 IN / 4 OUT (digital), Wi-Fi
<b>Electrical parameters</b>	
Alimentatore	100 ÷ 240 V AC 50 / 60 Hz
<b>Environmental conditions</b>	
temperatura di lavoro	+15 ÷ +30 °C
Temperatura di stoccaggio	-25 - +70 °C
Umidita atmosferica	10% ÷ 85% RH no condensation

\* Wi-Fi® is a registered trademark of Wi-Fi® Alliance.



## Accessori

Stampanti di ricevuta  
lettore di codici a barre  
stampanti per etichette  
Cavo di alimentazione con spina per accendisigari  
tavoli antivibranti per bilance industriali  
Hub USB  
Display  
cavi IN/OUT

tastiera, interruttori esterni  
Supporto, set di montaggio a muro e braccetti di montaggio  
Pesi standard F1 - cilindrico, set  
AP2-1 Power loop output  
Cavo seriale RS 232, RS 485  
RS 232 – USB Converter  
Cavo seriale RS 232 (connessione bilance - Stampanti EPSON)

## software

Sistema E2R  
Audit Trail Reader  
RADWAG Connect  
RADWAG Remote Desktop  
Studio di sviluppo RADWAG  
Editore per sistemi di pesatura 2.0

RAD-KEY  
Driver LabVIEW  
Editore di etichette R02  
R-LAB  
Codice a barre R

# Device dimensions

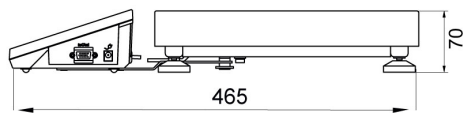

F1 version

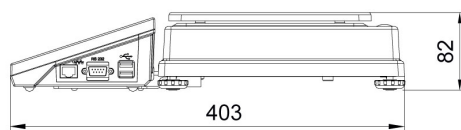
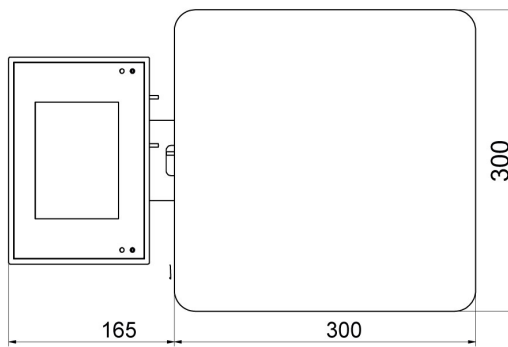

D2 version

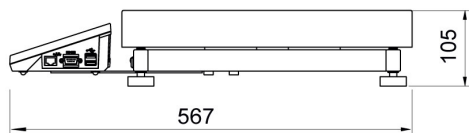
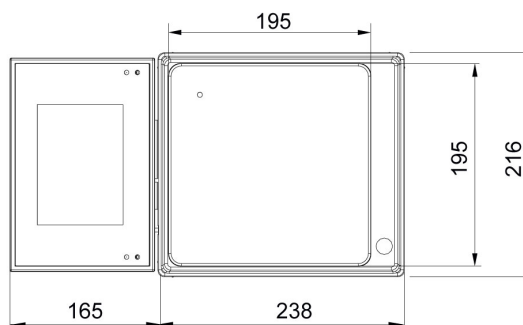

C2 version

